

ELECTRICAL SPECIFICATIONS:

- 1.) FREQUENCY RANGE: 0.7 - 2.7 GHz
- 2.) IMPEDANCE: 50 OHMS
- 3.) INSERTION LOSS (MAX): 0.4 dB (ABOVE 3.01 dB SPLIT)
- 4.) AMPLITUDE BALANCE (MAX): 0.2 dB
- 5.) PHASE BALANCE (MAX): 3 DEGREES
- 6.) ISOLATION (MIN): 22 dB
- 7.) INPUT VSWR (MAX): 1.25 : 1
- 8.) OUTPUT VSWR (MAX): 1.15 : 1
- 9.) DC VOLTAGE (MAX): 50 VOLTS

MECHANICAL SPECIFICATIONS:

- 1.) CONNECTORS: TYPE-N FEMALE (JACK), 50 OHM
- 2.) CONNECTOR BODY: BRASS, TRI-ALLOY PLATE
- 3.) CONNECTOR PIN: PHOSPHOR BRONZE, GOLD PLATE
- 4.) INSULATOR: PTFE, VIRGIN ELECTRICAL GRADE
- 5.) HOUSING: ALUMINUM, CLEAR CHEM CONVERSION FILM, RoHS COMPLIANT (NO HEX CHROM)
- 6.) SOLDER: LEAD FREE, RoHS COMPLIANT
- 7.) OPERATING TEMP: -65°C TO +85°C
- 8.) WEIGHT: 173 GRAMS

INPUT POWER RATING (POWER DIVIDER SPLITTER):

INTO MATCHED LOAD VSWR's	IN-PHASE	180° OUT-OF-PHASE
1.2 : 1	40 WATTS	40 WATTS
2.0 : 1	40 WATTS	10 WATTS
∞	20 WATTS	1 WATT

INPUT POWER RATING (POWER COMBINER):

COHERENT SIGNALS (IN-PHASE)	2 X 20 WATTS
COHERENT SIGNALS (180° OUT-OF-PHASE)	2 X 0.5 WATTS
NON-COHERENT SIGNALS	2 X 1 WATT
OTHER CONDITIONS - CONSULT FACTORY	

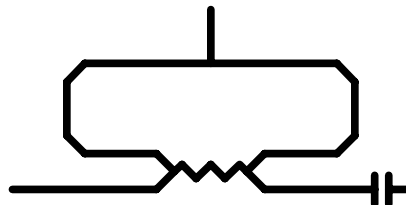
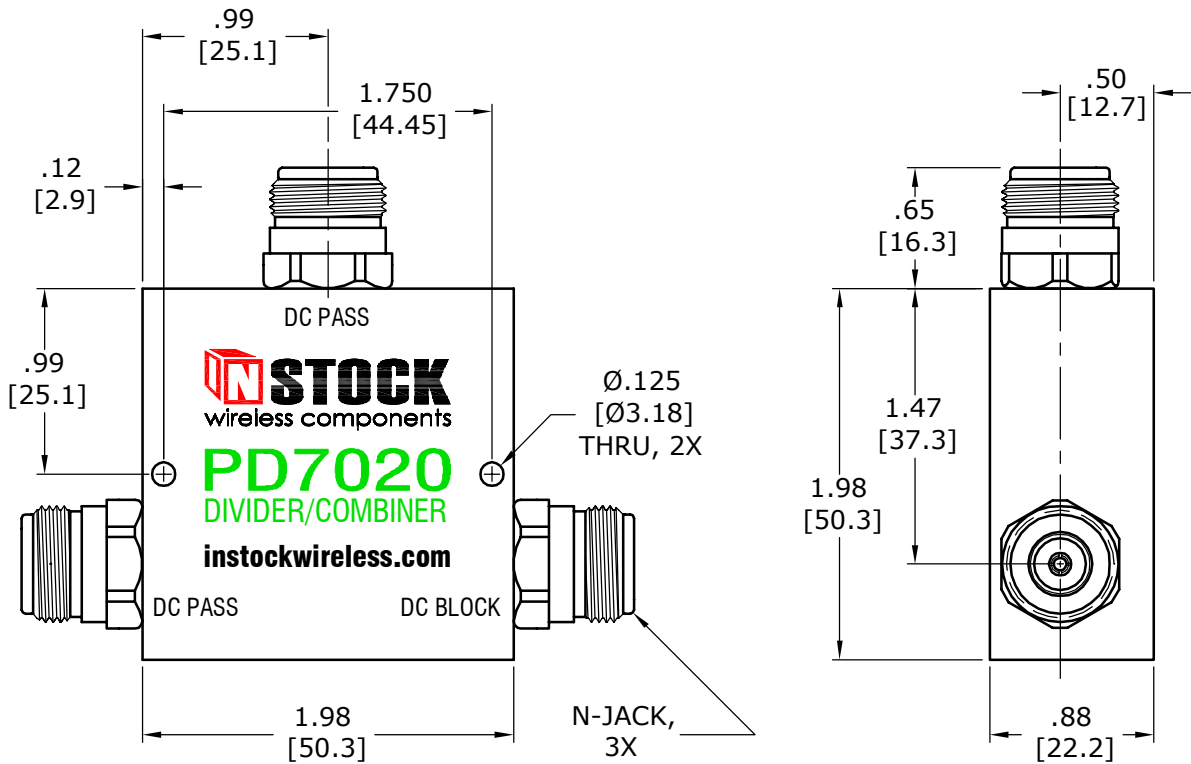

2-way, DC blocking power divider-splitter; DC pass 1 output, DC block 1 output. Typically used for powering an active antenna through the power divider-splitter.

REV	DESCRIPTION	BY	DATE	TOLERANCES		DRAWN: MJD DATE: 12/24/07	APPROVED: EMM DATE: 12/24/07	www.instockwireless.com	MODEL NO. PD7020	TITLE DC BLOCKING POWER DIVIDER, 2 WAY, T-STYLE, N-TYPE JACK, 0.7 - 2.7 GHz, 40 WATT, RoHS, DC BLOCK 1 OUTPUT.
				INCHES	MILLIMETERS					
				.00 = ±.01 .000 = ±.004	.0 = ±.25 .00 = ±.10					