

ELECTRICAL SPECIFICATIONS:

- 1.) FREQUENCY RANGE: 700 - 2700 MHz
- 2.) IMPEDANCE: 50 OHMS
- 3.) INSERTION LOSS (MAX): 0.4 dB (ABOVE 3.01 dB SPLIT)
- 4.) AMPLITUDE BALANCE (MAX): 0.2 dB
- 5.) PHASE BALANCE (MAX): 2 DEGREES
- 6.) ISOLATION (MIN): 22 dB
- 7.) INPUT VSWR (MAX): 1.20 : 1
- 8.) OUTPUT VSWR (MAX): 1.15 : 1

MECHANICAL SPECIFICATIONS:

- 1.) CONNECTORS: TYPE N FEMALE (JACK), 50 OHM
- 2.) CONNECTOR BODY: BRASS, TRI-ALLOY PLATE
- 3.) CONNECTOR PIN: PHOSPHOR BRONZE, GOLD PLATE
- 4.) INSULATOR: PTFE, VIRGIN ELECTRICAL GRADE
- 5.) HOUSING: ALUMINUM, CLEAR CHEM FILM
- 6.) SOLDER: LEAD FREE, RoHS COMPLIANT
- 7.) PROTECTION RATING: IP67 WATER AND WEATHER RESISTANT
- 8.) OPERATING TEMP: -65°C TO +85°C
- 9.) WEIGHT: 258 GRAMS

RF INPUT POWER RATING (POWER DIVIDER SPLITTER):

INTO MATCHED LOAD VSWR's	IN-PHASE	180° OUT-OF-PHASE
1.2 : 1	40 WATTS	40 WATTS
2.0 : 1	40 WATTS	10 WATTS
∞	20 WATTS	1 WATT

RF INPUT POWER RATING (POWER COMBINER):

COHERENT SIGNALS (IN-PHASE)	2 X 20 WATTS
COHERENT SIGNALS (180° OUT-OF-PHASE)	2 X 0.5 WATTS
NON-COHERENT SIGNALS	2 X 1 WATT
OTHER CONDITIONS - CONSULT FACTORY	

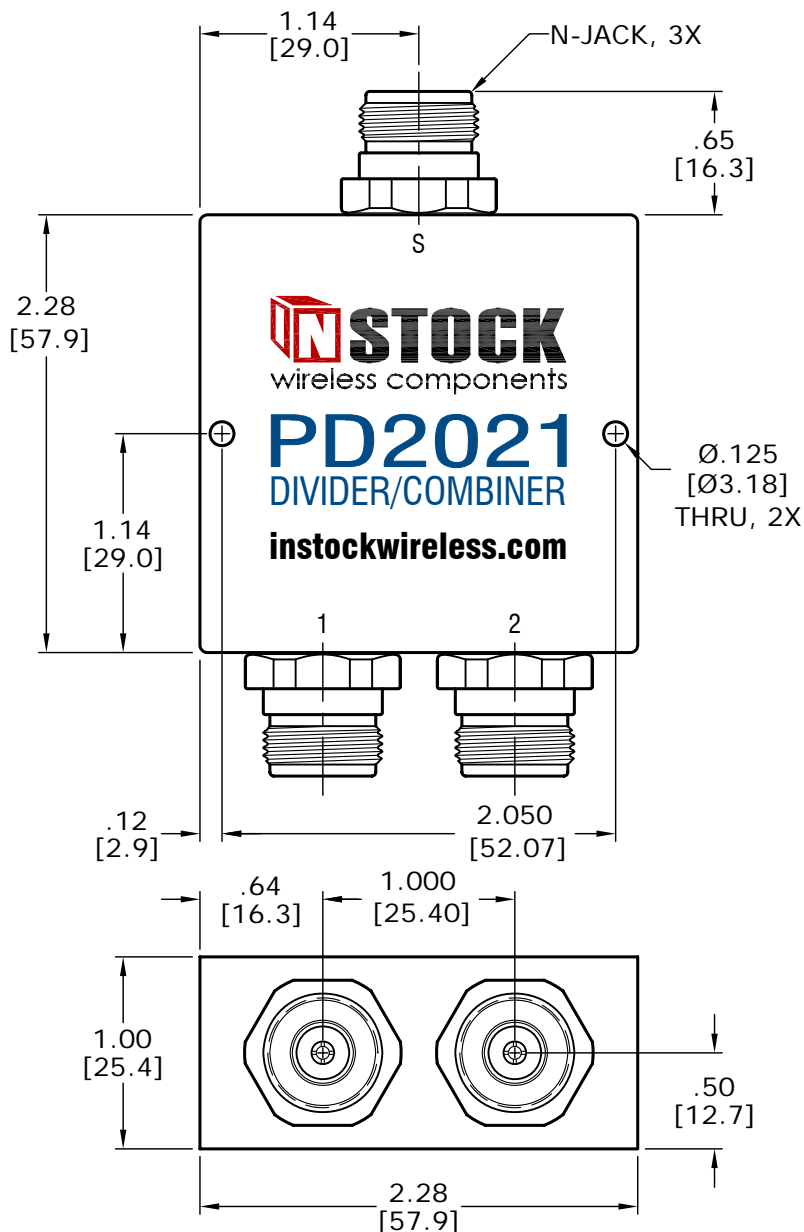

REV	DESCRIPTION	BY	DATE

TOLERANCES	
INCHES	MILLIMETERS
.00 = ±.01	.0 = ±.25
.000 = ±.004	.00 = ±.10
DRAWN: MJD	APPROVED: EMM
DATE: 07/01/08	DATE: 07/01/08

INSTOCK
wireless components
www.instockwireless.com

MODEL NO.	PD2021
TITLE	2 WAY POWER DIVIDER COMBINER, N TYPE JACK, 0.7-2.7 GHz, 40W, 50 OHM, IN-PHASE, RoHS, IP67 WEATHERPROOF