

ELECTRICAL SPECIFICATIONS:

- 1.) FREQUENCY RANGE: 0.7 - 2.7 GHz
- 2.) IMPEDANCE: 50 OHMS
- 3.) INSERTION LOSS (MAX): 0.7 dB (ABOVE 4.77 dB SPLIT)
- 4.) AMPLITUDE BALANCE (MAX): 0.3 dB
- 5.) PHASE BALANCE (MAX): 4 DEGREES
- 6.) ISOLATION (MIN): 22 dB
- 7.) INPUT VSWR (MAX): 1.35 : 1
- 8.) OUTPUT VSWR (MAX): 1.15 : 1
- 9.) DC VOLTAGE (MAX): 50 VOLTS

MECHANICAL SPECIFICATIONS:

- 1.) CONNECTORS: TYPE-N FEMALE (JACK), 50 OHM
- 2.) CONNECTOR BODY: BRASS, TRI-ALLOY PLATE
- 3.) CONNECTOR PIN: PHOSPHOR BRONZE, GOLD PLATE
- 4.) INSULATOR: PTFE, VIRGIN ELECTRICAL GRADE
- 5.) HOUSING: ALUMINUM, CLEAR CHEM CONVERSION FILM, RoHS COMPLIANT (NO HEX CHROM)
- 6.) SOLDER: LEAD FREE, RoHS COMPLIANT
- 7.) OPERATING TEMP: -65°C TO +85°C
- 8.) WEIGHT: 251 GRAMS

INPUT POWER RATING (POWER DIVIDER SPLITTER):

INTO MATCHED LOAD VSWR's	IN-PHASE	180° OUT-OF-PHASE
1.2 : 1	40 WATTS	40 WATTS
2.0 : 1	40 WATTS	10 WATTS
∞	20 WATTS	1 WATT

INPUT POWER RATING (POWER COMBINER):

COHERENT SIGNALS (IN-PHASE)	3 X 13.3 WATTS
COHERENT SIGNALS (180° OUT-OF-PHASE)	3 X 0.33 WATTS
NON-COHERENT SIGNALS	3 X 0.66 WATTS
OTHER CONDITIONS - CONSULT FACTORY	

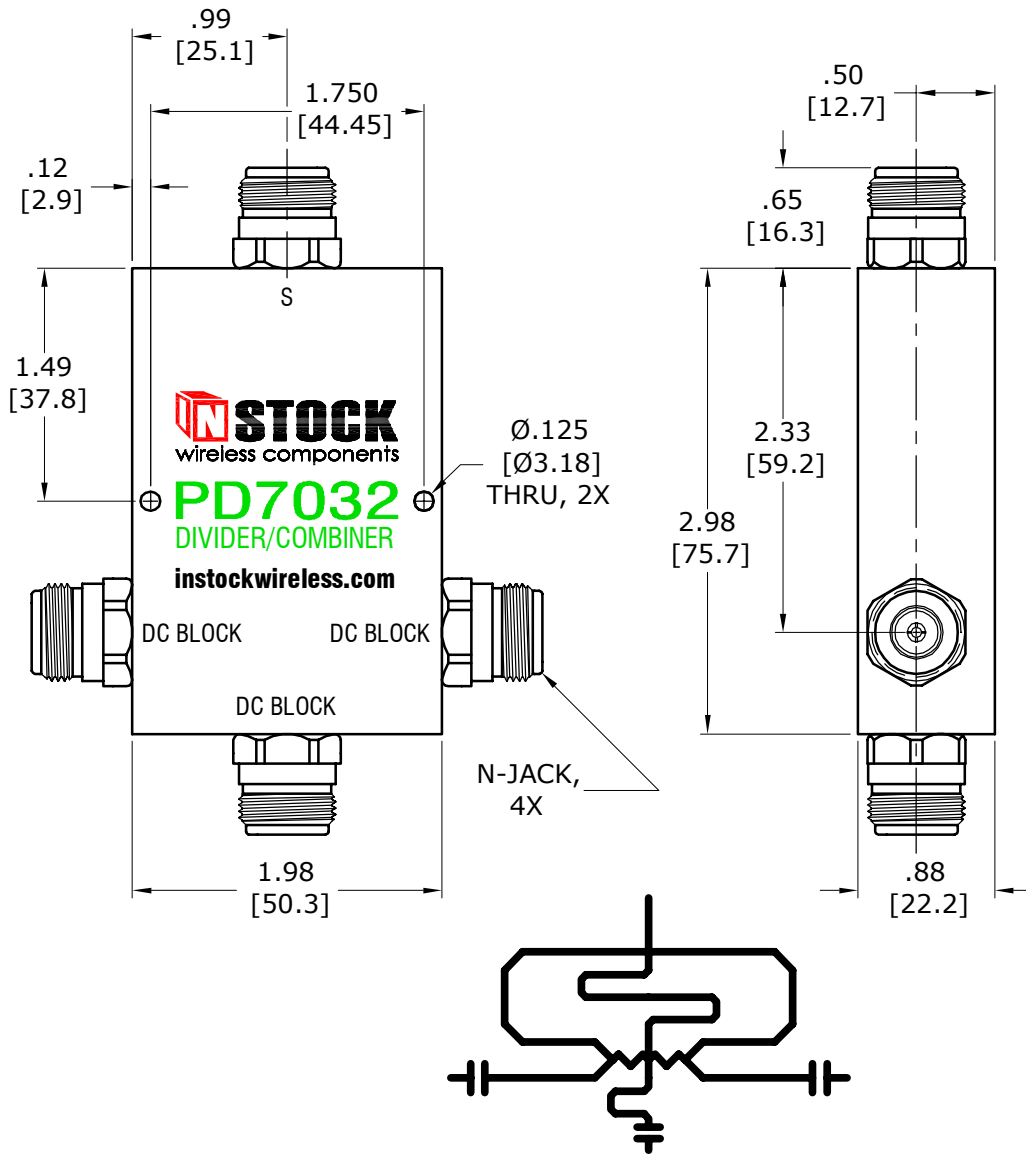

3-way, DC blocking power combiner; DC block input ports. Typically used to prevent passing DC current in combining applications to sum or other inputs.

REV	DESCRIPTION	BY	DATE

TOLERANCES	
INCHES	MILLIMETERS
.00 = ±.01	.0 = ±.25
.000 = ±.004	.00 = ±.10
DRAWN: MJD	APPROVED: EMM
DATE: 12/16/07	DATE: 12/16/07

STOCK
wireless components
www.instockwireless.com

MODEL NO.	PD7032
TITLE	DC BLOCKING POWER COMBINER, 3 WAY, T-STYLE, N-JACK, 0.7-2.7 GHz, 40 WATT, RoHS. DC BLOCK INPUTS.